



Software-Defined Radio, Redefined.

The Barrett 4050 HF SDR transceiver is the centrepiece of the Barrett range of HF communications equipment. It combines Software-Defined Radio technology with the intuitive "ease of use" that has become synonymous with the Barrett name. When teamed with other Barrett HF products, the versatile Barrett 4050 transceiver provides secure email, data transfer and telephone connectivity within a HF network and outwards to international telephone and internet networks.

The Barrett 4050 transceiver can be controlled from all major mobile and desktop platforms. The Barrett 4050 remote control app supports iOS, Android and Windows devices for wireless voice and radio control.



- Advanced fully software-defined architecture
- Intuitive and user-friendly touch-screen interface
- IP Connectivity
- Wireless operation via iOS, Android & Windows devices
- USB connection for transceiver programming and key fill
- Multi-Language software interface
- Digital Voice and Secure Digital Voice
- On-board high speed data transmission waveforms
- Detachable wired and wireless control head connectivity
- Up to 150W transmit power
- Superior receiver performance
- Low current consumption
- 2G & 3G Automatic Link Establishment (ALE)
- GPS Push option
- Backwards compatible with existing radio networks
- ED-137C Interoperability Standard¹

4050



Barrett 4050 HF SDR front panel

Software-Defined Architecture

The Barrett 4050 transceiver's advanced Software-Defined architecture provides complete software control of RF modulation and bandwidths, providing unprecedented flexibility and reliability with ease of upgrade. Custom emissions and filter bandwidths of up to 4 kHz can be enabled with a simple swipe of the touchscreen.

High Resolution Touch Screen Control

 Access to the most advanced intuitive HF Radio interface on the market via a super bright high definition 24-bit colour touchscreen providing maximum view ability under all lighting conditions.

Digital and Secure Digital Voice (optional)

 Digital Voice (DV) can improve the reliability of communications over noisy channels where reception of analogue voice can be very poor. Voice can be improved markedly by the use of digital voice modules to the point where barely usable frequencies are made clear. Secure Digital Voice (SDV) allows users to encrypt their communications over HF radio providing a secure HF network. Barrett offer two SDV encryption standards. A non-export controlled DES 56 vocoder with rates of 700, 1200 and 2400bps or an export controlled AES 256 vocoder with rates of 600, 1200 and 2400bps. Both deliver cutting edge voice communication performance and security at all times.



Barrett 4050 HF SDR rear panel

Enhanced DSP Noise Reduction

 The digital signal processor (DSP) provides clear intelligible voice communications on analogue circuits through the digital removal of background noise and interference. The DSP noise reduction system provides outstanding voice quality by reducing radio frequency interference, and the effects of electrical interference by enhancing audio signals to provide clearer communication.

Multi-Language Menu

Change the Barrett 4050 language setting at the touch of a button. Each radio ships with multiple language menus including English, French, Spanish, Arabic, Russian, Turkish and Chinese.



Frequency Hopping (optional)

 The unique, easy to use Frequency Hopping* option requires no central synchronisation station, has no entry or late entry time delay and requires no handshaking. Available hopping rates of 5 or 25 hops per second, the use of an 8 digit hopping encryption key, with a user selectable hopping bandwidth to suit a variety of antenna types, the system provides excellent protection against electronic warfare (EW) attacks and can be operated for extended periods in the field without synchronisation.

Integrated GPS Interface



 Barrett's GPS interface supports connection of any NMEA 0183 external GPS receiver antenna for tracking applications. This interface enhances emergency call features and position information on all deployed equivalently equipped HF assets. Combined with Barrett's soon to be released GPS Push tracking solution, Barrett can provide unrivalled asset tracking performance over HF.

Advanced Calling Features

 The Barrett 4050 transceiver is fully interoperable with advanced digital selective calling systems commonly used by many peacekeeping and non-government organisations globally. The Barrett 4050 transceiver provides four and six digit selective call features, including telephone interconnect, SMS text, GPS tracking, status calling, point to point and/or multipoint secure call and remote transceiver disable capabilities.



Automatic Link Establishment (optional)

  Backwards compatible 2nd generation (2G) ALE, based on MIL-STD-188-141B (JITC certified) and FED-STD-1045, is available as an option for automatic point-to-point and/or multipoint calling including telephone interconnect, AMD text messaging and GPS position. For superior fast link setup (FLSU), robust packet data and greater penetration on noisy channels, 3rd generation (3G) ALE based on STANAG 4538 is also available.

Data Modems Capability

Multiple data waveform options are provided in the Barrett 4050 including MIL-STD-188-110A/B (STANAG 4285, 4415, 4481, 4529, 4539), CLOVER 2500, CLOVER 3000 and the forthcoming CLOVER NG standard. Combined with Barrett's latest Digital Transmission software and intuitive user interface, these waveforms provide unparalleled performance with "throughput" rates up to and in excess of 19200 bps.



Barrett 4050 HF SDR remote head configuration

IP Network Connectivity

 Built into the 4050 control head, the wireless access point allows mobile cellular handsets, tablets and desktop PCs to connect directly to the transceiver over Wi-Fi using the optional Wi-Fi adaptor. Advanced Barrett 4050 to IP adaptors provide optional Ethernet connectivity to additional IP configurations.

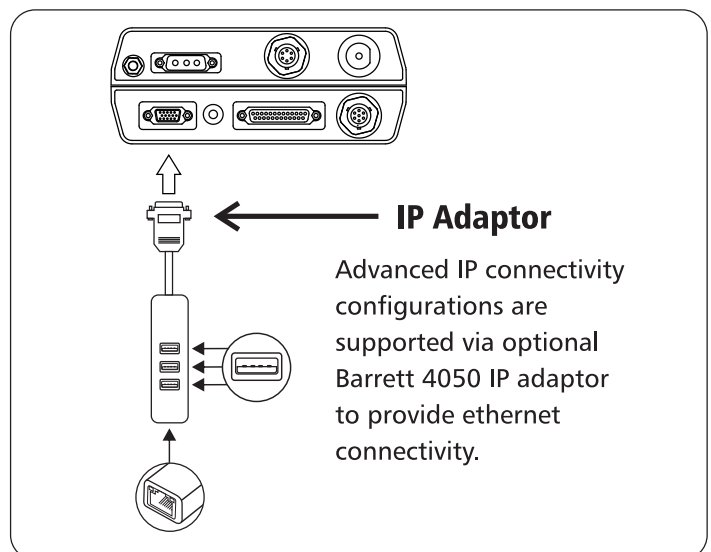
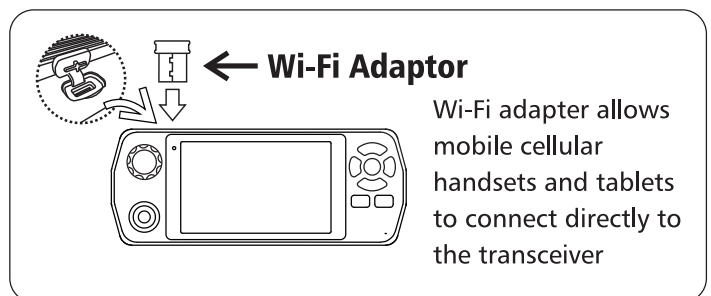

*Subject to export controls

4050

Dual Port Antenna Switch Unit

The Barrett Dual Port Antenna Switch Unit provides the capability for two antennas and antenna tuning units (ATU's) to be connected to the 4050 HF SDR Transceiver. The selection of each antenna (one or two) is made within the 4050's software interface and the individual antennas can be assigned to individual channels (frequencies).

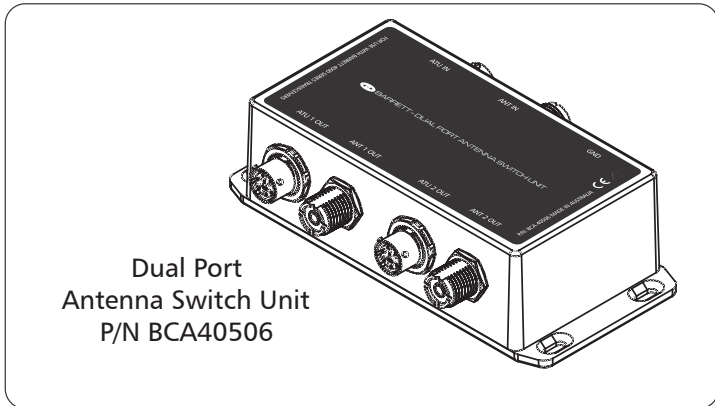

4050 HF Transceiver - General Specifications

TX Frequency Range	1.6MHz – 30MHz
RX Frequency Range	250KHz – 30MHz
Channel Capacity	1000
Frequency Stability	± 0.5 PPM -30°C to +70°C (±0.1 PPM available optionally)
Frequency Resolution	10 Hz program mode; 1 Hz tunable receiver
Operating Modes	J3E (USB, LSB) - H2B (AM) - J2A (CW) - CF (Custom Filter) - ISB (data option)
Filter Bandwidths	Fully Software-Defined standard and custom filter range from 300Hz to 3000Hz and beyond.
Operating Temperature	-30° to +70°, relative humidity 95%, non condensing
Frequency Hopping	5 or 25 hops per second
Supply Voltage	+11V DC or +28V DC operation
Selcall System	Based on CCIR 493-4, 4 and 6 digit systems
ALE Standards	2G & 3G ALE
Current Consumption	350mA standby (muted)
Sensitivity	-125dBm (0.12 µV) for 10dB SINAD
RF Output Power	150W PEP (with 24V supply) 125W PEP (with 12V supply)
Duty Cycle	100% data with fan option
Standards	Designed to meet or exceed: <ul style="list-style-type: none"> - FCC – Part 87 and Part 90 - CE - Australia/New Zealand AS/NZS 4770 2000 and AS/NZS 4582:1999 and AS 60529:2004 - EMC and vibration Standard IEC 945 - Designed to meet Mil-STD 810G for temperature, humidity, altitude, shock, vibration and IP54 - NTIA - J1TC

Specifications are typical. Equipment descriptions and specifications are subject to change without notice or obligation.
¹ Available Q1 2020

4050 remote control head
(trunk mount configuration)
Weight 0.35 kg

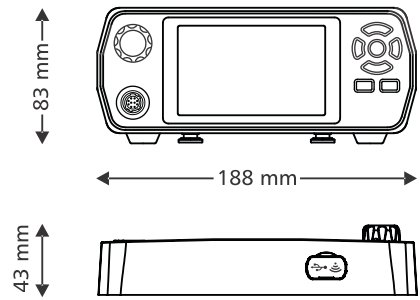

4050 remote control configuration
(trunk mount) main unit
Weight 2.2 kg

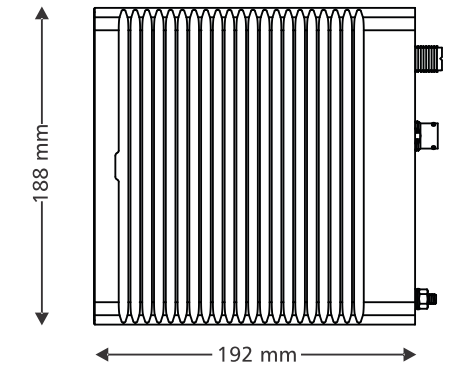

4050 local control configuration
Weight 2.55 kg

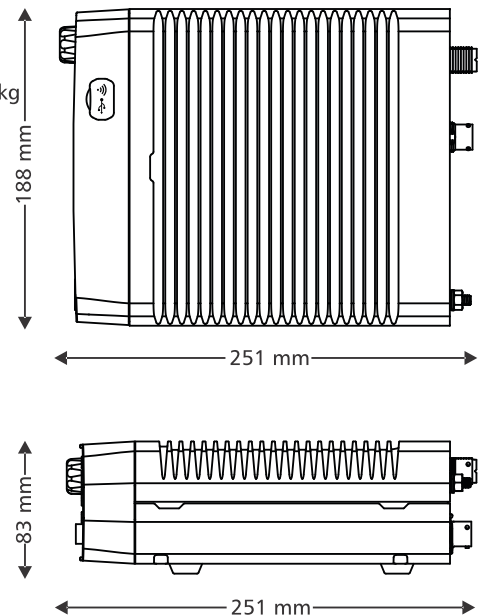

BCB40500/11



Head Office:
Barrett Communications Pty Ltd
47 Discovery Drive, Bibra Lake,
WA, 6163 AUSTRALIA
Tel: +61 8 9434 1700
Fax: +61 8 9418 6757
Email: information@barrettcommunications.com.au